

SERIES BOP



Analog Meters
Model BOP 50-2M (top) and BOP 100-4M (bottom)
100, 200 and 400 Watt Linear High-Speed Amplifiers



Digital Meters
Model BOP 20-5D (top) and BOP 72-6D (bottom)
100, 200 and 400 Watt Linear High-Speed Amplifiers

BOP, while fully rated power supplies, are also high-powered operational amplifiers with full 4-quadrant, bipolar operation. Their output is capable of both sustained d-c and the replication of arbitrary a-c waveforms.

In Kepeco's BOP, the voltage and current outputs can be controlled smoothly and linearly through the entire rated plus and minus ranges, passing smoothly through zero with no polarity switching.

BOP are high speed power operational amplifiers that can be used to provide dynamically agile voltage for test and simulation. They are *not* general purpose power supplies. By the nature of the bipolar high speed design, they do not have any energy-storage noise discriminating output capacitors. To realize the full high speed potential of BOP, the load characteristics should be mainly resistive. If the load is capacitive, (>0.1 microfarad), the BOP must be slowed to avoid oscillation. This is accomplished in voltage mode by increasing the value of the feedback capacitance. Special terminals on the user port are available to slow the BOP for optimum current-mode stability into inductive loading.

BOP MODEL TABLE

MODEL(1) (5)	d-c OUTPUT RANGE		CLOSED LOOP GAIN		OUTPUT IMPEDANCE			
	E_o max.	I_o max.	VOLTAGE CHANNEL G_V (V/V)	CURRENT CHANNEL G_I (A/V)	VOLTAGE MODE SERIES R	CURRENT MODE SERIES L(2)	VOLTAGE MODE SHUNT R	CURRENT MODE SHUNT C(3)
100 WATT								
BOP 20-5M	± 20V	± 5A	2.0	0.5	80μΩ	20μH	40kΩ	0.05μF
BOP 50-2M	± 50V	± 2A	5.0	0.2	0.5mΩ	100μH	50kΩ	0.05μF
BOP 100-1M	± 100V	± 1A	10.0	0.1	2.0mΩ	200μH	100kΩ	0.05μF
200 WATT								
BOP 20-10M	± 20V	± 10A	2.0	1.0	40μΩ	50μH	20kΩ	0.1μF
BOP 36-6M	± 36V	± 6A	3.6	0.6	120μΩ	50μH	36kΩ	0.1μF
BOP 50-4M	± 50V	± 4A	5.0	0.4	0.25mΩ	100μH	50kΩ	0.05μF
BOP 72-3M	± 72V	± 3A	7.2	0.3	0.48mΩ	200μH	72kΩ	0.05μF
BOP 100-2M	± 100V	± 2A	10.0	0.2	1.0mΩ	200μH	100kΩ	0.05μF
BOP 200-1M(4)	± 200V	± 1A	20.0	0.1	4.0mΩ	1.2mH	200kΩ	0.03μF
400 WATT								
BOP 20-20M	± 20V	± 20A	2.0	2.0	20μΩ	50μH	20kΩ	0.2μF
BOP 36-12M	± 36V	± 12A	3.6	1.2	60μΩ	50μH	36kΩ	0.2μF
BOP 50-8M	± 50V	± 8A	5.0	0.8	125μΩ	100μH	50kΩ	0.15μF
BOP 72-6M	± 72V	± 6A	7.2	0.6	240μΩ	200μH	72kΩ	0.1μF
BOP 100-4M	± 100V	± 4A	10.0	0.4	500μΩ	200μH	100kΩ	0.1μF

- (1) For factory installed digital interfaces add appropriate suffix. See page 55.
 (2) For determining dynamic impedance in voltage mode.
 (3) For determining dynamic impedance in current mode.
 (4) Same size as 400W models.
 (5) To specify digital display, substitute the suffix letter "D" for the suffix letter "M."

FEATURES

- Source and sink 100% of their current rating. See Figure 1.
- Separate control circuits for voltage and current with automatic crossover to current and voltage limits.
- All controls and flag signals accessible through a 50-terminal user-port at the rear.
- Zeroable preamplifier available for scaling and summing external signals.
- Optional digital displays. Specify by substituting the suffix "D" in place of the "M."



For high power bipolar power supplies, see Series BOP High Power, page 44.

For high voltage bipolar power supplies, see Series BOP-HV, page 56.

The tabulation of the effective series resistance and inductance in voltage mode, and the effective shunt resistance and shunt capacitance in current mode, is done to allow a calculation of the output impedance versus frequency.

BOP accept plug-in cards for remote digital control

- BIT 4882 provides 12-bit IEEE 488.2 talk-listen control with SCPI support.
- BIT 4886 provides 16-bit IEEE 488.2 talk-listen control with SCPI support.
- BIT TMA-27 connect BOP to Kepco's single-address multiple instrument serial bus for long range (>300m) control from IEEE 488.2, RS 232 or VXI-based hosts.
- BIT 488B or BIT 488D offer listen-only GPIB support in binary or Hex format.

Cards may be factory installed. See page 55 for appropriate suffix designations.



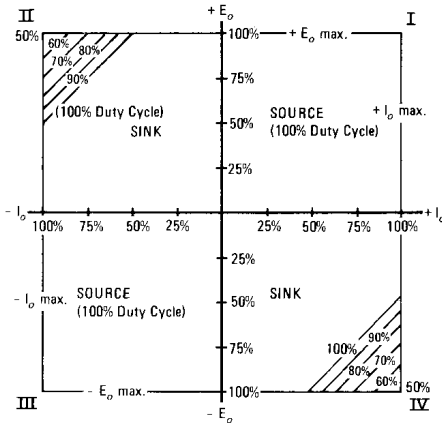



FIGURE 1
Output Source-Sink plot

TABLE 1
Source current measured worst case, 125V a-c.

MODEL	CURRENT (Amps)
BOP 20-5M	2.6
BOP 20-10M	5.5
BOP 20-20M	11.0
BOP 36-6M	5.1
BOP 36-12M	10.6
BOP 50-2M	2.6
BOP 50-4M	4.8
BOP 50-8M	9.5
BOP 72-3M	5.0
BOP 72-6M	10.8
BOP 100-1M	2.6
BOP 100-2M	4.8
BOP 100-4M	9.2
BOP 200-1M	5.5

 BOP are CE marked per the Low Voltage Directive (LVD), EN61010-1.



BOP GENERAL SPECIFICATIONS

SPECIFICATION	RATING/DESCRIPTION	CONDITION
INPUT		
a-c Voltage	95-113, 105-125, 190-226, 210-250V a-c	User selectable
Current	See Table 1	Max load, 115V a-c
Frequency	47-65Hz	Range
OUTPUT		
d-c Output	Bi-direction, series pass	Transistor ⁽¹⁾
Type of stabilizer	Automatic crossover	Voltage/current
Voltage	0 to 100% of rating (bipolar)	Adjustment range for temp 0-55°C
Current	0 to 100% of rating (bipolar)	
Sink	See source/sink plot	Duty cycle
Error Sense	0.5V per load wire	Voltage allowance
Isolation Voltage	500V d-c or peak	Output to ground
Leakage Current	<5 microamperes	rms at 115V a-c 60Hz
Output to Ground	<50 microamperes	p-p at 115V a-c 60Hz
Series Connection	500V	Max voltage off ground
Parallel Connection	Current sharing	Use master-slave connection
OVP	Not available	
CONTROL		
Type	Voltage Current	Variable input, fixed gain
Voltage/ Current	Local	
	Remote Analog	10-turn zero-center pot
	Local Digital	Serial bus or GPIB or VXI
	Remote Digital	Use SN or SNR interface
Bounding	±Volt/current local	Four screwdriver trimmers
	±Volt/current remote	0 to 10 volts
Dynamics	See dynamic spec table	Fast only
User Amplifiers	Uncommitted gain 20K	Two provided
References	±10 volts, 1mA	Two provided
Options (built-in) For user added card refer to "BIT" models page 55	GPIB hex card	Suffix -488B
	GPIB BCD card	Suffix -488D
	Long range serial card/VXI	Suffix -TMA
	Talk-listen 4882 card (SCPI)	Suffix -4882
	Talk-listen 4886 card (SCPI)	Suffix -4886
	Serial RS 232	Suffix -232
MECHANICAL		
Input Connection	Detachable IEC type 3-wire	All models
Output Connections	Front signal/output	Binding posts
	Rear user port	50-terminal connector
	Rear output	Barrier strip
Meters	Two 2½" horiz., 2% zero center analog	Front panel
Indicators	Four LEDs	Voltage/Current/Bounding
Mounting (in std 19" racks)	Use RA 37 rack adapter	¾ rack size
	Mounting "ears" supplied	Full rack size
Cooling	Forced air	Exhaust to rear
Dimensions (HxWxD) add 2½" to rear for connector	inches mm	¾ rack size
	5 7/32 x 12 17/32 x 17 9/64 132.6 x 318.3 x 435.4	
	5 7/32 x 19 x 20 5/64 132.6 x 482.6 x 510	Full rack size
Finish; Fed Std 595	Light gray, color 26440	Front panel
Weight (packed for shipment)	47lb (21.4Kg)	¾ rack size (100W)
	53lb (24.1Kg)	¾ rack size (200W)
	76lb (34.5Kg)	Full rack size

(1) 200V model uses FET.

BOP DYNAMIC SPECIFICATIONS

MODEL	BANDWIDTH (d-c to f _{-3dB}) KHz (minimum) Mode		RISE & FALL TIME 10%-90% µsec (maximum) Mode		LARGE SIGNAL FREQUENCY (min) RESPONSE, KHz Mode		SLEWING RATE (minimum) Mode		RECOVERY STEP LOAD µsec (maximum) Mode	
	V	I	V	I	V	I	V	I	V	I
100 WATT										
BOP 20-5M	18	12	20	30	17	13	5V/µsec	0.15A/µsec	25	10
BOP 50-2M	18	12	20	30	17	13	5V/µsec	0.15A/µsec	25	10
BOP 100-1M	18	11	17	22	18	11	11V/µsec	70mA/µsec	40	25
200 WATT										
BOP 20-10M	18	6	20	60	17	7	2V/µsec	0.4A/µsec	80	20
BOP 36-6M	16	13	20	27	15	14	3V/µsec	0.5A/µsec	50	35
BOP 50-4M	23	14	14	25	15	11	4.5V/µsec	0.25A/µsec	40	30
BOP 72-3M	20	15	18	26	17	12	10V/µsec	0.15A/µsec	30	30
BOP 100-2M	22	15	18	26	17	12	10V/µsec	0.15A/µsec	30	30
BOP 200-1M	4.0	2.5	110	150	4.0	2.5	5V/µsec	15mA/µsec	150	120
400 WATT										
BOP 20-20M	9.5	10	35	35	8	10	1V/µsec	1.25A/µsec	100	75
BOP 36-12M	20	10	16	30	19	10	4V/µsec	0.75A/µsec	50	30
BOP 50-8M	16	10	22	35	24	11	7.5V/µsec	0.5A/µsec	40	30
BOP 72-6M	19	9.5	18	40	20	11	9V/µsec	0.4A/µsec	50	20
BOP 100-4M	18	14	22	30	16	10	10V/µsec	0.25A/µsec	40	30

BOP STATIC SPECIFICATIONS

INFLUENCE QUANTITY	OUTPUT EFFECTS(1)				PREAMPLIFIER(4) OFFSETS		REFERENCE ± 10V
	VOLTAGE MODE		CURRENT MODE		ΔE _{io}	ΔI _{io}	
	TYPICAL	MAXIMUM	TYPICAL	MAXIMUM			
Source (min.-max.)	<0.0005%	0.001%	<0.002%	0.005%	<5µV	<1nA	<0.0005%
Load (NL-FL)	<0.001%	0.002%	<0.5mA	1mA	—	—	<0.0005%
Time (8-hour drift)	<0.005%	0.01%	<0.01%	0.02%	<20µV	<1nA	<0.005%
Temp., per °C	<0.005%	0.01%	<0.01%	0.02%	<20µV	<1nA	<0.005%
Ripple and Noise (2)	rms	<1mV	3mV(5)	<0.01%	0.03%	—	—
	p-p(3)	<10mV	30mV(5)	<0.1%	0.3%	—	—

- (1) Output effects, expressed as a percentage, are referred to the maximum rated output voltage or current.
- (2) Measured with the common terminal grounded so that the common mode current does not flow through the load.
- (3) Peak-to-peak ripple is measured over a 20Hz to 10MHz bandwidth.
- (4) The output effect can be calculated by the relationship:

$$\Delta E_o = \pm \Delta E_r (R_f/R_i) \pm \Delta E_{io} (1+R_f/R_i) \pm \Delta I_{io} (R_f)$$
 where R_f is the feedback resistor, and R_i is the input resistor from the reference, E_r.
- (5) For BOP 200-1M the maximum ripple and noise is 5mV rms and 50mV p-p.

The tabulated offsets, more particularly their change as a function of source, time and temperature, allow a user to calculate performance of the uncommitted amplifier(s) with user specified input and feedback components. The formula for this is given in the static specifications table footnote.





OUTLINE DIMENSIONAL DRAWINGS

Fractional dimensions in light face type are in inches, dimensions in bold face type are in millimeters.

Tolerance: ± 1/64" (0.4) between mounting holes
± 1/32" (0.8) other dimensions

100 & 200 WATT MODELS
(THREE-QUARTER RACK)

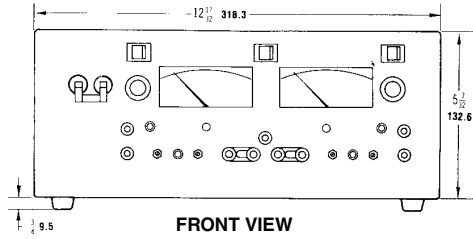

FRONT VIEW

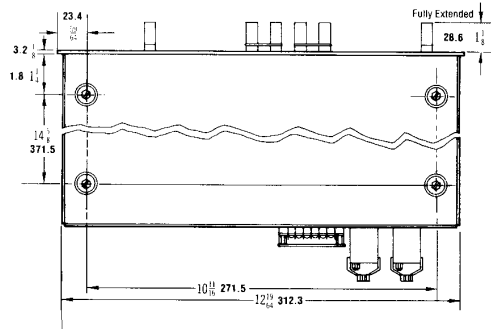

BOTTOM VIEW

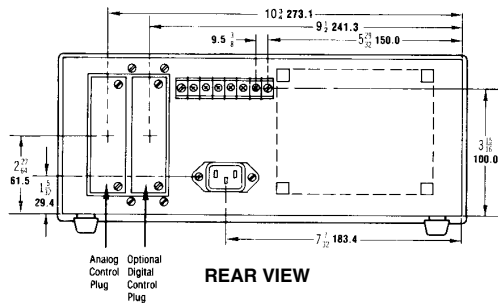

REAR VIEW

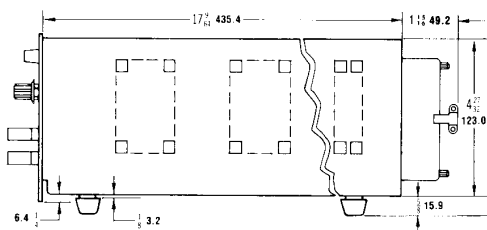

SIDE VIEW

400 WATT MODELS (FULL RACK)
AND BOP 200-1M

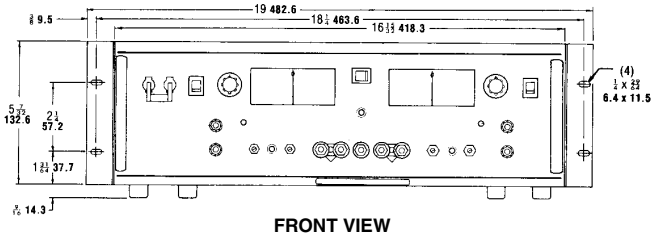

FRONT VIEW

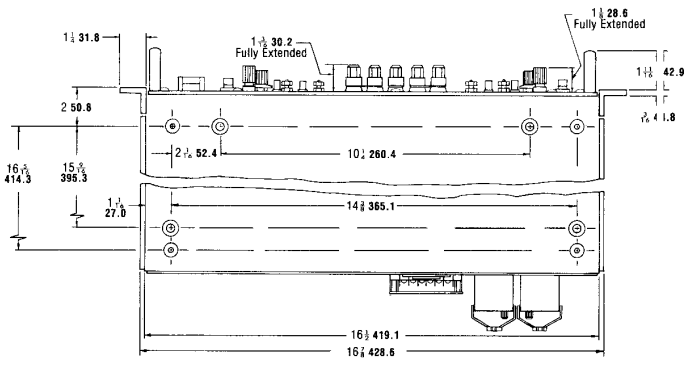

BOTTOM VIEW

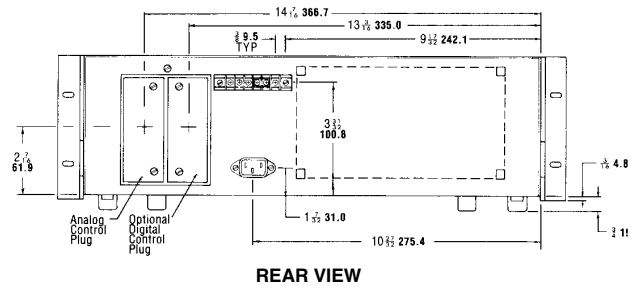

REAR VIEW

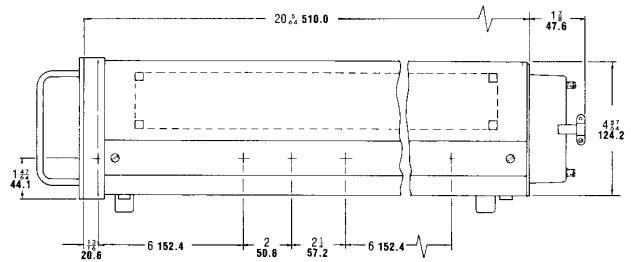

SIDE VIEW

BOP 3/4 rack width power supplies can be rack mounted using RA 37. See page 77.